

Bearing Fault Detector

Monitor and Detect Bearing Faults to Avert Catastrophic Failure

- Provides Early Warning of Bearing and Gear Faults
- Detects Impacting Associated with Spalling, Cracking, and Lubrication Problems
- Outputs 4 to 20 mA Signals for Peak Acceleration and Overall Vibration
- Operates with PLC, DCS, SCADA, Alarm, and Control Systems
- Offers Analog Output Signal for Spectral Analysis and Diagnostics
- Conducts Continuous Vibration Monitoring — 24/7
- Accepts Input from ICP® Accelerometers
- Patented Technology
- Easy to Install



Model 682A05
Bearing Fault Detector
*(US Patent Number 6,889,553)

Model 682A05 Bearing Fault Detector (BFD) is an advanced vibration signal conditioner designed to provide the earliest warning of imminent machinery failure. The unit works with a 100 mV/g ICP® accelerometer and serves to deliver two, 4 to 20 mA output signals that are proportional to the measured vibration levels of operating rotating machinery. In order to enable detection of a wide variety of machinery faults, the 4 to 20 mA signals are conditioned to characterize two, unique vibration measurements; one containing high frequency peak data and the other containing low frequency rms data. These 4 to 20 mA signals may be monitored, alongside other plant process variables, using familiar PLC, DCS, SCADA, alarm, and control systems. An additional analog voltage output signal is provided for spectral analysis of the monitored vibration for fault diagnostic purposes.

The unit employs a patented signal conditioning technique that provides the unique ability to detect bearing and gear problems at their earliest stages, thus permitting ample maintenance planning to avert a catastrophic failure. The simplified 4 to 20 mA signal monitoring approach represents a cost effective alternative to complex vibration monitoring instrumentation and associated training.

As with all IMI instrumentation, this equipment is complemented with toll-free applications assistance, 24-hour customer service, and is backed by a no-risk policy that guarantees satisfaction or your money refunded.



Introduction

Machinery vibration monitoring has long been recognized as an effective practice for detecting mechanical problems that ultimately cause machinery failure and downtime. Unfortunately, many instrumentation systems that are intended to assist the maintenance engineer with vibration analysis are complex — and require considerable training and experience in order to interpret measurement data. Too often, companies may encounter the loss of an experienced maintenance engineer due to downsizing or attrition — leaving critical machinery to run without being monitored and expensive analysis equipment to lay idle.

In recent years, industrial accelerometers have advanced in performance capability and declined in price, making their deployment for machinery vibration monitoring a more attractive undertaking. Additionally, vibration transmitters, with 4 to 20 mA output signals, have permitted vibration monitoring to occur with plant process control equipment, such as PLCs, alarm, and control systems, thus reducing the expense, complexity, and risk of talent loss associated with sophisticated vibration analysis. Although not as precise as analog vibration signal analysis, overall vibration level monitoring with IMI Sensors' 4 to 20 mA transmitters is effective for providing early warning of machinery trouble.

Why use IMI Sensors' 4 to 20 mA vibration transmitters?

Industrial plants rely on monitoring, control, and alarm systems for interrogating many process variables, such as flow, level, temperature, pH, and pressure. Although a variety of communication protocols are in use, 4 to 20 mA transmitters are the common source for the measurement data of interest. When machinery vibration is considered within the list of variables in need of evaluation, the existing infrastructure of process monitoring and control instrumentation becomes an attractive choice for data examination. To accommodate this, a variety of 4 to 20 mA vibration transmitters have been introduced. These transmitters may be incorporated within the vibration sensor — or separately housed in a signal-conditioning package. Depending on the amplitude and frequency of the vibration to be monitored, the vibration data can be most successfully characterized in acceleration, velocity or displacement units of measure — so the output format of a vibration transmitter should be selected accordingly for best results.

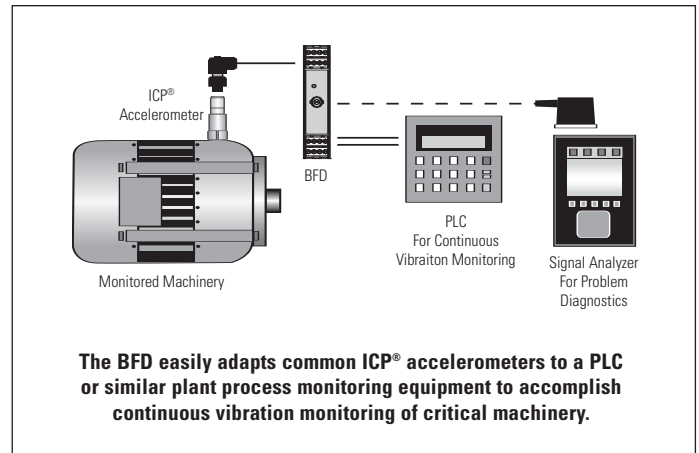

What makes IMI Sensors' BFD different?

The IMI Sensors Model 682A05 BFD is a signal conditioner characterized as a separately housed vibration transmitter. The unit mounts to DIN rail and accepts an analog vibration signal as generated from a 100 mV/g ICP® accelerometer. Three different vibration output signals are provided by the BFD — (1) the raw, analog voltage signal generated by the accelerometer; (2) a low frequency, linear, 4 to 20 mA signal proportional to overall rms or peak vibration and expressed as either acceleration or velocity; and (3) a logarithmically scaled, 4 to 20 mA signal proportional to high-frequency, captured peak acceleration. It is this third output signal that makes the BFD unique, powerful, and patented.

The benefit of this unique measurement signal is its ability to respond, with significant change, when short duration bursts of energy manifest into a vibration signal. These bursts are indicative of bearing and gear problems, yet are so short in duration that they have little influence on an overall vibration signal, as provided by signal type (2) above. This unique capability enables the BFD to provide the earliest warning of bearing and gear problems through an ordinary 4 to 20 mA signal. This permits the user to initiate the diagnostic and maintenance process sooner in order to avoid a catastrophic and costly machinery failure.

What are the signal conditioning techniques utilized by the BFD?

Output signal type (1) is the raw, analog voltage signal generated by the accelerometer. Since the BFD is scaled to operate with a 100 mV/g ICP® accelerometer, this output signal will be approximately 100 mV/g or, more precisely,



the exact sensitivity for the specific accelerometer connected to the BFD. This analog signal is provided on the BNC jack output BFD and is useful for spectral FFT analysis of the vibration signal for fault diagnostics.

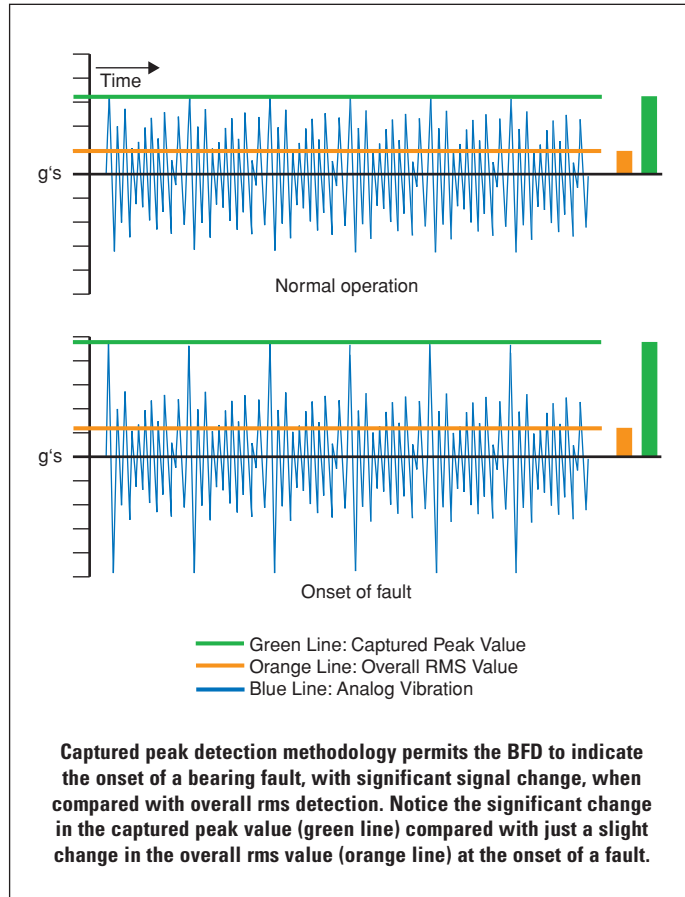

Output signal type (2) is a linear, 4 to 20 mA signal proportional to overall, low frequency, rms or peak vibration. Internal selection switches allow a choice of acceleration or velocity measurements, peak or rms values, and a variety of fixed measurement ranges. The signal

generated by the accelerometer is initially processed through a 1 kHz low pass filter. Then when set for velocity, the BFD passes this filtered signal through an integration circuit. When set for acceleration, the filtered signal bypasses the integration circuit. At the next stage, the signal passes through a true RMS conversion circuit. Finally, a gain stage provides scaling of the velocity or acceleration signals to one of a variety of fixed full-scale measurement ranges. Another gain adjustment converts the rms measurement value to a *calculated* peak measurement value, if desired. This overall vibration signal is a useful indicator of faults that occur at machine running speeds, such as imbalance, misalignment, and looseness.

Output signal type (3) is a logarithmically scaled, 4 to 20 mA signal proportional to high frequency, captured peak acceleration. The signal generated by the accelerometer is initially processed through a high pass filter, selectable at either 1 kHz or 5 kHz, depending upon machine running speed. To accommodate a wide measurement range, the acceleration signal is then rectified and compressed into a logarithmic scale. Consequently, it should be noted that the resultant 4 to 20 mA signal is not linearly proportional to peak acceleration. The peak acceleration value that occurs within a 7-second window is then captured by a sample and hold circuit and converted to a 4 to 20 mA output signal. A new value is captured during the next window and a refreshed peak output value is generated every 7 seconds. This peak acceleration signal is a useful indicator of impacting or high-frequency energy bursts — characteristic of the early stages of bearing and gear faults, such as spalling, friction, fatigue, cracking, contamination, and lubrication problems.

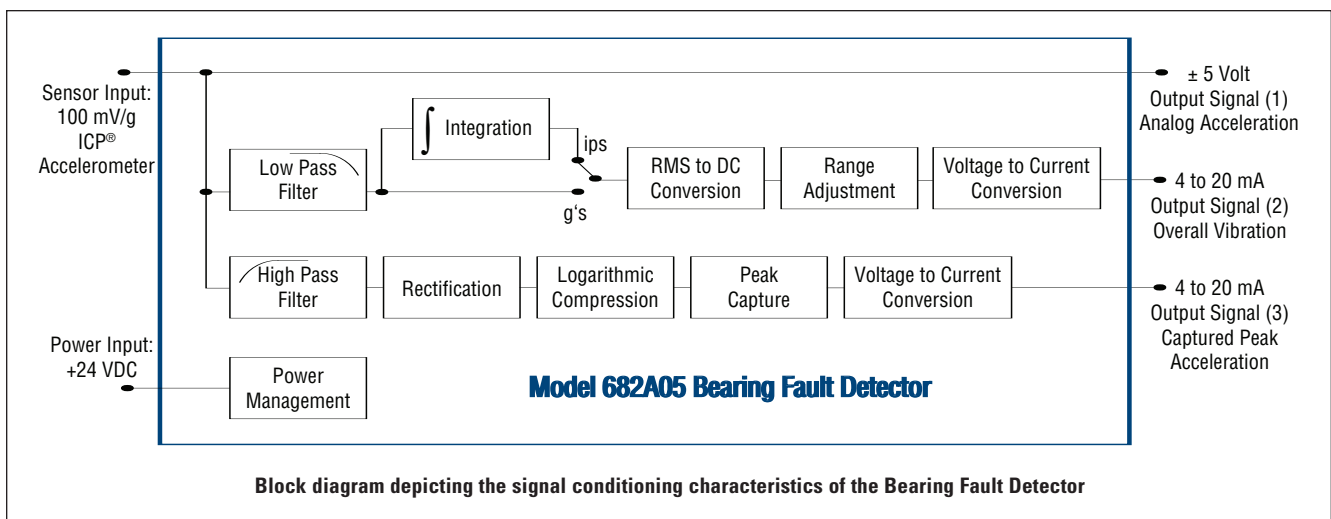



MODEL 682A05 BEARING FAULT DETECTOR

Specifications

Model		682A05	
Performance		English	SI
Channels		1	1
Input Signal	(ICP® Accelerometer)	100 mV/g	10.2 mV/m/s ²
Output Signals			
	Raw, Analog Vibration	100 mV/g	10.2 mV/m/s ²
	Overall Vibration (range is user scalable)	4 to 20 mA	4 to 20 mA
	Captured Peak Acceleration (± 50 g, log scale)	4 to 20 mA	4 to 20 mA
Measurement Range			
	Raw, Analog Vibration	± 50 g	± 491 m/s ²
	Overall Vibration set for Acceleration (selectable)	5.0, 10.0, 20.0 g pk or rms	
	Overall Vibration set for Velocity (selectable)	0.5, 1.0, 2.0 ips pk or rms	
	Captured Peak Acceleration	± 50 g pk	± 491 m/s ² pk
Frequency Range			
	Raw, Analog Vibration	as per sensor used	as per sensor used
	Overall Vibration	10 to 1000 Hz	10 to 1000 Hz
	Captured Peak Acceleration	1 or 5 kHz to 100 kHz	1 or 5 kHz to 100 kHz
Time Constant / Refresh Rate (Captured Peak)		7 sec	7 sec

Environmental			
Temperature Range	(Operating)	+32 to +159 °F	0 to +70 °C
Temperature Range	(Storage)	-40 to +257 °F	-40 to +125 °C
Humidity Range	(Non-Condensing)	<95 %	<95 %

Electrical			
Power Required		24 VDC	24 VDC
Current Draw	(Max)	150 mA	150 mA
Settling Time	(Max)	1 min	1 min
Excitation Voltage	(Delivered to Sensor)	24 VDC (± 1 VDC)	24 VDC (± 1 VDC)
Constant Current Excitation	(to Sensor)	4 mA (± 1 mA)	4 mA (± 1 mA)

Physical			
Electrical Connector	(Input/Output/Power)	Removable Screw Terminals	Removable Screw Terminals
	(Raw, Analog Vibration Output)	BNC Jack	BNC Jack
Wire Size Accommodated at Screw Terminals		24-14 AWG	24-14 AWG
Status Indicator	(Power On)	Green	Green
Housing Material		Polyamide	Polyamide
Size (h x w x d)		3.9 x 0.9 x 4.5 in	99 x 22.5 x 114.5 mm
Weight		5.2 oz	145.2 gm
Mounting		1.38 in DIN Rail	35 mm DIN Rail

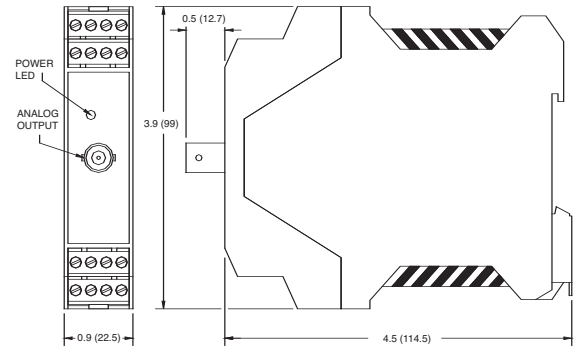

**Model 682A05
Bearing Fault Detector**

Dimensions shown are in inches (millimeters)

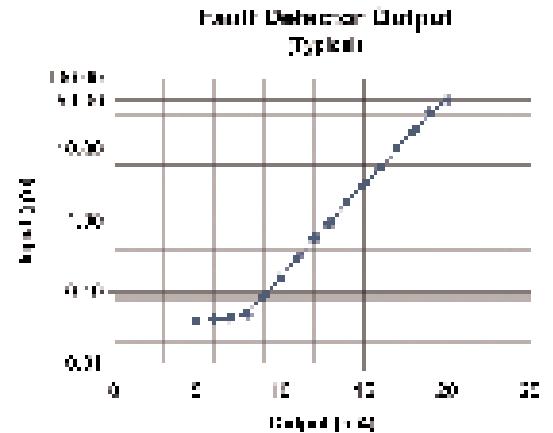

The captured peak value is compressed into a logarithmic scale to encompass a large amplitude range. This plot depicts the non-linear, logarithmic conversion of the captured peak voltage to a 4 to 20 mA output signal.



3425 Walden Avenue, Depew, NY 14043-2495 USA

IMI Sensors Division toll free 800-959-4464

24-hour SensorLineSM 716-684-0003

Fax 716-684-3823 E-mail imi@pcb.com

Web site www.imi-sensors.com

ISO 9001:2000 CERTIFIED

A2LA ACCREDITED to ISO 17025

© 2007 PCB Group, Inc. In the interest of constant product improvement, specifications are subject to change without notice.
PCB, IMI with associated logo, ICP, Swiveler, and Spindler are registered trademarks of PCB Group, Inc.
SensorLine is a service mark of PCB Group, Inc. All other trademarks are properties of their respective owners.

IMI-682A05-0607

Printed in U.S.A.

The IMI Sensors Division of PCB® Piezotronics, Inc. specializes in the development, application, and support of industrial vibration sensors, transmitters, meters, and accessories for machinery condition monitoring and predictive maintenance requirements. This product focus, coupled with the strengths and resources of PCB, permits the IMI Sensors Division to offer exceptional customer service, 24-hour technical assistance, and a **Total Customer Satisfaction** guarantee.

Visit www.imi-sensors.com to locate your nearest sales office